

Static electricity

1. A student did an experiment with two strips of polythene. She held the strips together at one end. She rubbed down one strip with a dry cloth. Then she rubbed down the other strip with the dry cloth. Still holding the top ends together, she held up the strips.



(a) (i) What movement would you expect to see?

.....

(1)

(ii) Why do the strips move in this way?

.....

(2)

(b) Complete the **four** spaces in the passage.

Each strip has a negative charge. The cloth is left with a.....
 charge. This is because particles called have been transferred
 from the to the

(4)

(c) The student tried the experiment using two strips of aluminium. The strips did not move. Complete **each** of the sentences.

(i) Materials, such as aluminium, which electricity will pass through easily, are called

(1)

(ii) Materials, such as polythene which electricity will **not** pass through easily, are called

(1)

(Total 9 marks)

2. A pupil did an experiment following the instructions below.

1. Take a polythene rod (AB), hold it at its centre and rub both ends with a cloth.
2. Suspend the rod, without touching the ends, from a stand using a stirrup and nylon thread.
3. Take a perspex rod (CD) and rub it with another cloth.
4. Without touching the ends of the perspex rod bring each end of the perspex rod up to, but without touching, each end of the polythene rod.
5. Make notes on what is observed.

The diagram below shows how the apparatus is to be set up.

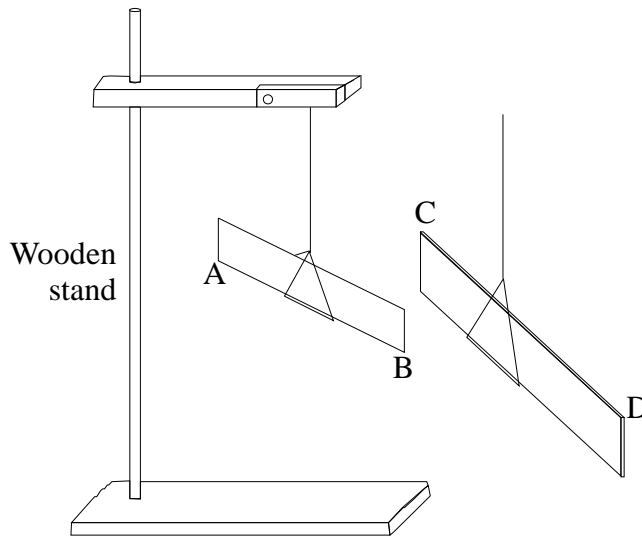

(a) When end C was brought near to end B they attracted each other.

(i) Explain why they attracted each other.

.....

(ii) What would happen if end C were brought near end A?

.....

(3)

(b) The experiment was repeated with two polythene rods.

(i) Describe what you would expect the pupil to observe as the end of one rod was brought near to the end of the other.

.....

(ii) Explain your answer.

.....

(2)

(c) Explain, in terms of electron movement, what happened as the rods were rubbed with the cloths.

.....

(3)
 (Total 8 marks)